

BERNINA®

Service Manual

english



minimatic serie

801 - 802 - 803

807 - 810 - 817

800 - 808 - 809

811 - 818

Contents

General information	3
Rest position of needle	6
Lateral displacement of needle	7
Setting notched segment	9
Shuttle adjustment	11
Return motion	13
Loop lift	14
Needle height	15
Material feed	16
Lift and advance	18
Presser foot adjustment	19
Adjustment of stitch setting link	21
Upper thread tension	23
Lower thread tension	24
Drive	27
Electrical fittings	27
Fault avoidance	31

BERNINA model 807

Zig-zag and plain stitch machine

BERNINA model 808

Zig-zag machine

BERNINA model 809

Straight stitch machine

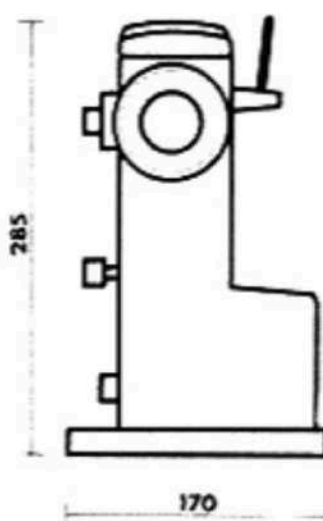
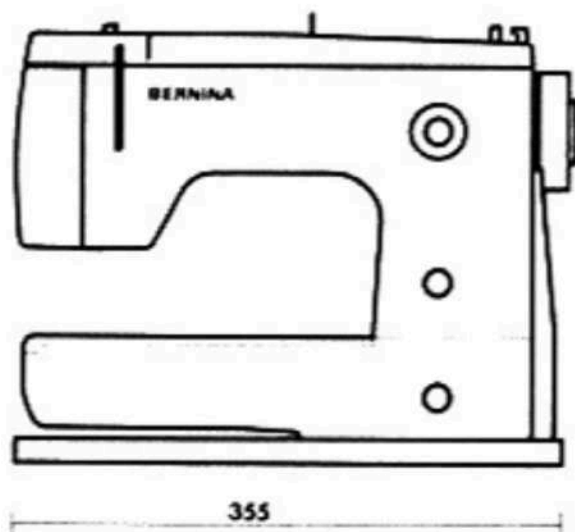

Max. zig-zag width

4.5 mm

Stitch distribution

left—center—right

Max. forward stitch length

4 mm

Max. reverse stitch length

2 mm

Presser foot lift

6,5 mm

Passage space

110 x 200 mm

Size of baseplate

355 x 170 mm

Shuttle system

non-stick central bobbin shuttle

Bobbin capacity

75 m cotton yarn

Needle system

705 B

Needle movement

swinging needle bar

Thread feed

hinged take-up lever

Thread tension

upper thread tensioning incorporated in frame cover

free manual
- for personal use only
not for sale, free
distribution allowed

 **BERNINA Oldtimer**
Rep. & Service Information
www.occaphot-ch.com

Manual © by Fritz Gegauf AG, Steckborn
BERNINA International AG

Winder

built-in

Motor A-2-707

power: 85 watts

Sewing lamp (built-in)

power: 15 watts

Number of stitches

approx. 1100 stitches/min.

Weight of machine (807)

8.1 kg

Weight complete with carrying case (807)

12.2 kg

Running-in needle	705 B - 80
Needle deflection:	
with lifting bar suspension	3
needle plate upper edge	4.5
at shuttle tip	4.63
Needle bar lift	33.73
Loop lift: left	2.2
Shuttle travel	220° 18' 30"
Rack travel	34.6
Lifting crank radius	17.3
Take-up lever travel	61
Presser foot lift	6.5
Darner lift	2.92
Speed:	
motor	7500 rpm
step pulley	2405 rpm
frame shaft	1137 rpm
Gear ratio:	
overall	6.6 : 1
motor: step pulley	3.12 : 1
step pulley: frame shaft	2.12 : 1
Base circumference	230 mm
Machine dimensions:	
overall length	360 mm
overall width	170 mm
height over adjusting lever	
weightest position	305 mm

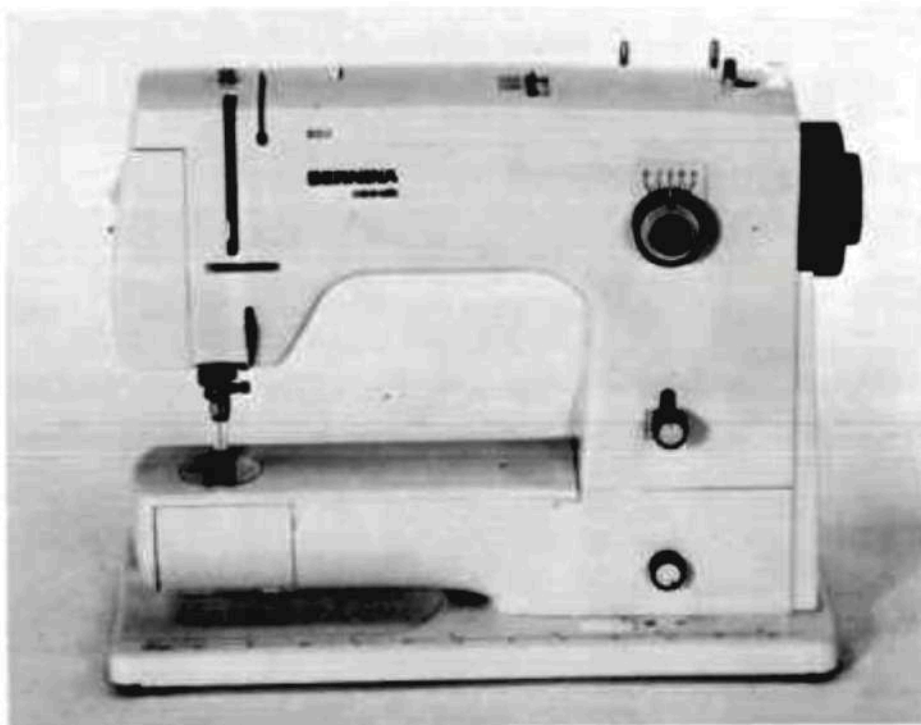

Fig. 2

Adjustment of Model 807 (and variants)

These instructions are designed to help you carry out minor repairs and adjustments to the BERNINA Model 807 sewing machine.

The booklet lays no claim to completeness. The instructions are not suitable for an overall mechanical assembly or dismantling procedure.

IMPORTANT: To enable the following points to be performed correctly, the sewing machine must be in **good mechanical condition** (running smoothly, properly oiled, etc.)

If the sequence of adjustments is observed the machine will operate fully satisfactorily.

The needle

The needle is one of the most important sewing items. It has the task of piercing the work and of taking the upper thread to the shuttle for linking with the lower thread and of forming the loop for acceptance by the shuttle.

The loop is formed after the needle has pierced the work and has reached its lowest point. The thread is drawn tight and lies in the long groove at the front. At the rear it lies in the short groove and higher up between the needle stem and the hole pierced in the fabric. If the needle rises slightly, the so-called loop-lift, a loop is produced at the eye of the needle on the short groove side which the tip of the shuttle can enter, as a result of the friction between the work and the needle stem where the thread is retarded.

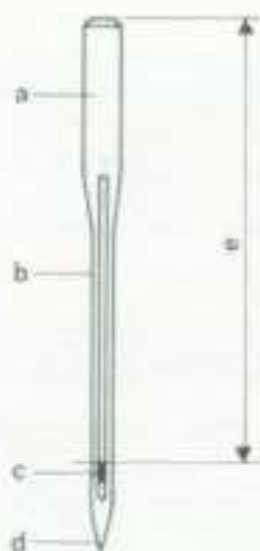

Basically, the sewing machine needle has the following features:

- a) the **shank** for securing the needle in the needle bar,
- b) the **stem** with a short and a long groove for guiding the thread and forming the loop,
- c) the **eye of the needle**
- d) the **point of the needle**
- e) the **needle length**.

BERNINA uses the «705 B» needle system without fluting (Singer designation: 15 x 1) on all domestic machines.

Since 1947 the millimetre system has been used for needle size. Needle size «100» means a needle stem thickness of 1 mm (Needle No. 80 = 0.8 mm dia.)

The needle must be **firmly** secured with the knurled screw on the needle holder.

IMPORTANT: Always use a needle No. 80 for all adjustments unless otherwise stated.

Check the needle before every adjustment to the machine. It must **always be straight**.

The needle plate

The needle plate is used to take the material to be worked and has a longitudinal slot, the stitch hole, to allow the needle to pass. It is hardened and polished to allow upper and lower threads to slide through smoothly. In addition, it is perforated in the shape of the feed dog which feeds the material.

Needle distribution in needle plate slot

The needle must penetrate at the center of the stitch hole as seen in the direction of the material feed. (Needle No. 90).

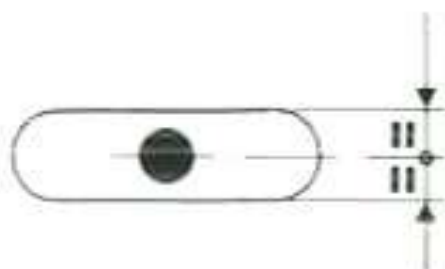

Fig. 2

If a correction has to be made, the belt cover must be removed on the handwheel side (see also page 27) and three of the four frame fixing screws loosened (socket

head screws with width of 5 mm). For this operation the special wrench No. 398 089 03 is required. Dismantle support plate from gearing. Then press the frame to the desired position and retighten the three screws.

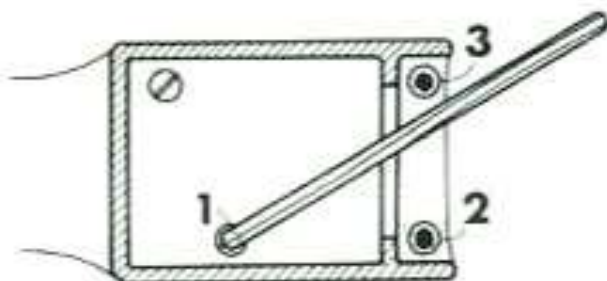

Fig. 3



Fig. 3 a



Fig. 4

Adjustment of link and stitch position

L—C—R (left—center—right)

Place the special tool No. 398 001 04 through the hollow link spindle while at the same time turning the L—C—R knob backwards and forwards until the conical tip of the tool engages with the hole of the link.

(See Fig. 4)

This ensures that the link in its normal position pivots around the center of the link spindle.

The L—C—R knob is fixed at the desired center position (zero position). In this position the red line on the front of the knob must be exactly vertical.

In the event of inaccuracy the socket head screw (9) with locknut should be loosened and the L—C—R knob set to its correct position.

Retighten socket head screw (9) and remove the tool.

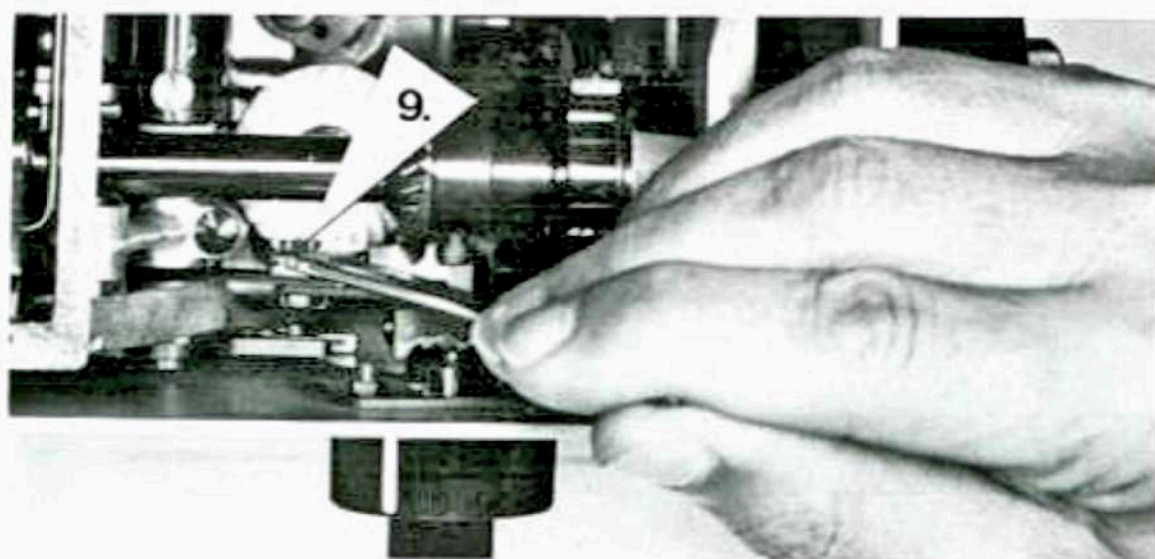

Fig. 5

Rest position of needle

Turn zig-zag knob fully to left — up to stop (position «0»). Start machine. The needle swivel support must not make any lateral movement.

It must remain stationary.

If this is not the case, correction is made as follows: screw (10) with conical locknut (11) in the guide fork (12) is loosened with the aid of special spanner No. 398 035 03 (or with a screwdriver for slotted nuts). Then adjust screw (10) up or down until the swivel support, and therefore the needle, remains absolutely still while the machine is running. Retighten locknut (11).

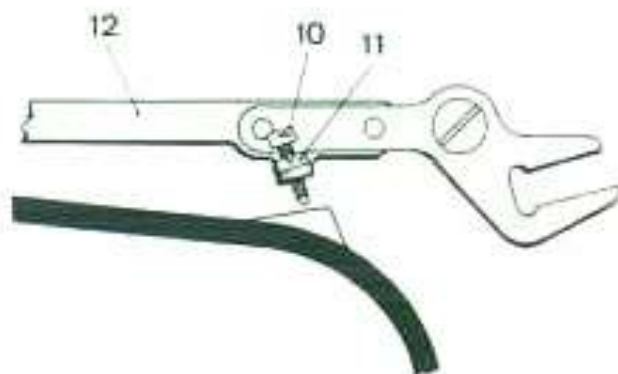

Fig. 6

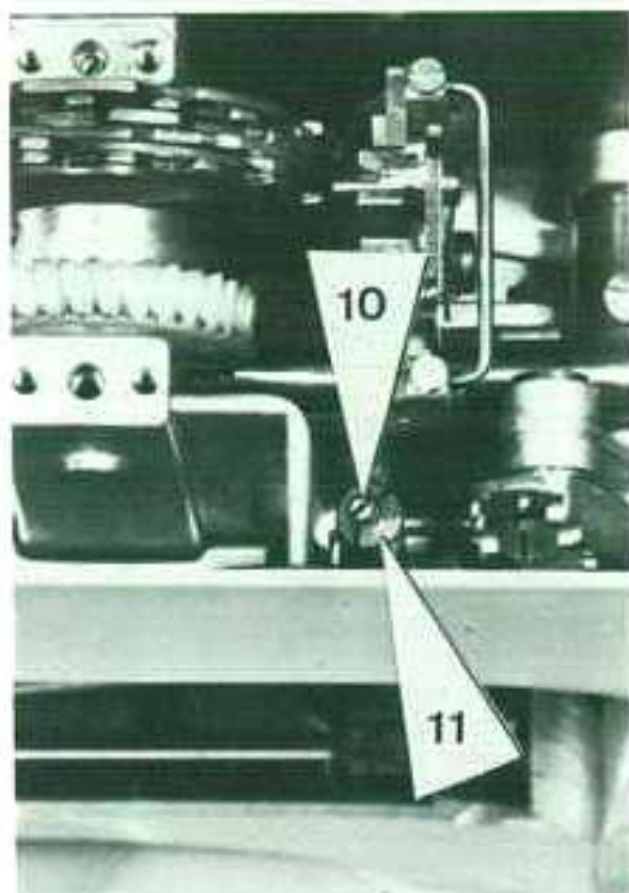

Fig. 6 a

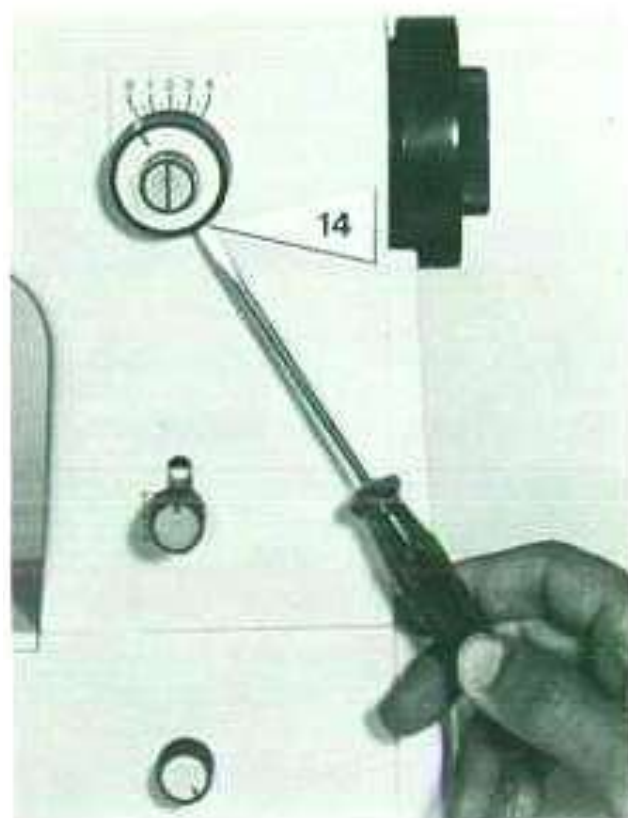

Fig. 7

When the rest position of the needle is corrected, check whether the white marking line of the zig-zag knob coincides with the «0» on the scale.

If not set exactly loosen screw (14) on the zig-zag knob and set the two marks (knob and scale) in alignment.

Retighten screw (14).

Lateral needle movement, transverse to material direction

The needle must pierce through the center of the stitch hole if the red mark on the LCR head is exactly vertical. This can easily be checked if the needle is observed while turning the LCR knob from the left to the right hand position.

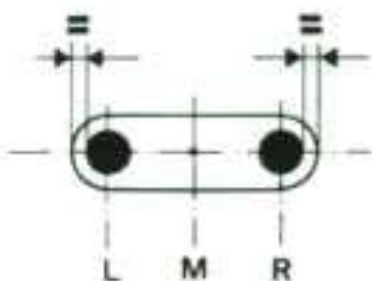

Fig. 8

The distance from the edge of the stitch hole must be the same in each case.

If not, it should be corrected as follows: Loosen screw (15). Place special fork key No. 398 063 03 on the knurled screw head (16). This screw (16) is formed as a small eccentric. By turning slightly to the right or left the lateral position of the needle can then be brought to the desired position. Screw (15) should be retightened following this correction.

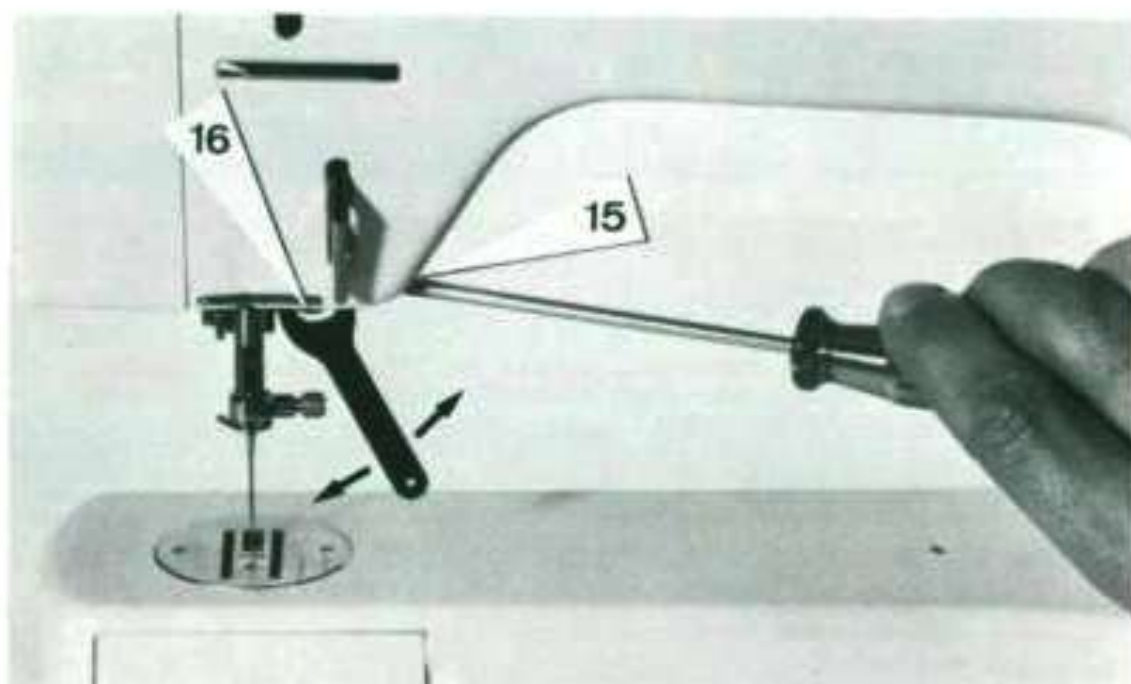

Fig. 9

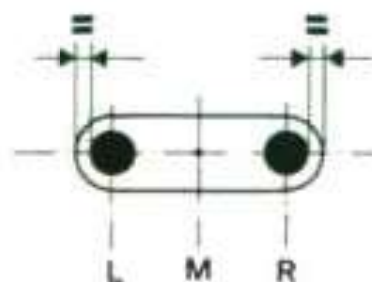

Fig. 10

Stitch position on zig-zag

Set the zig-zag knob to position 4 and observe while turning the handwheel whether the left and right hand penetration is equidistant from the edge of the stitch hole.

If this is not the case, loosen clamping screw (17) of the rocking lever (18) on which the zig-zag link is suspended and set the needle to the correct position.

IMPORTANT: Ensure when moving the rocker lever (18) that no play results between bearing and lever.



Fig. 11

Lateral motion of needle during zig-zag and plain stitch sewing

The lateral movement of the needle (parabola) must be exactly matched to the up and down motion. It may only begin when the needle has left the work and must cease when the needle pierces the work. The zig-zag motion is derived from an eccentric

Check:

Set LCR knob to center position.

Set plain stitch selector lever (29) on eccentric No. 1 (zig-zag).

Set needle to uppermost position by turning handwheel. If the zig-zag knob is then turned backwards and forwards between «0» and «4» the needle must remain stationary.

If not, a correction must be made.

If this is not the case a correction must be made.

Loosen the two screws on worm wheel (20). Then, using the screwdriver, secure the worm wheel (20) which is loose on the spindle while pressing the setting ring (21) and turning the handwheel until the correct setting is found (Fig 11).

Tighten the two screws on the worm wheel.

Setting notched carrier segment

The notched carrier (38) limits the needle deflection in such a way that when the scanner is raised the needle cannot pierce anywhere outside the stitch hole.

The notched carrier must be attached so that when the plain stitch selector lever

is moved from cam 1 to cam 6 the needle always pierces at the same distance from the left-hand stitch hole edge (zig-zag knob at position 4).

The three screws (40, 41, 42) must be loosened to make any adjustment.

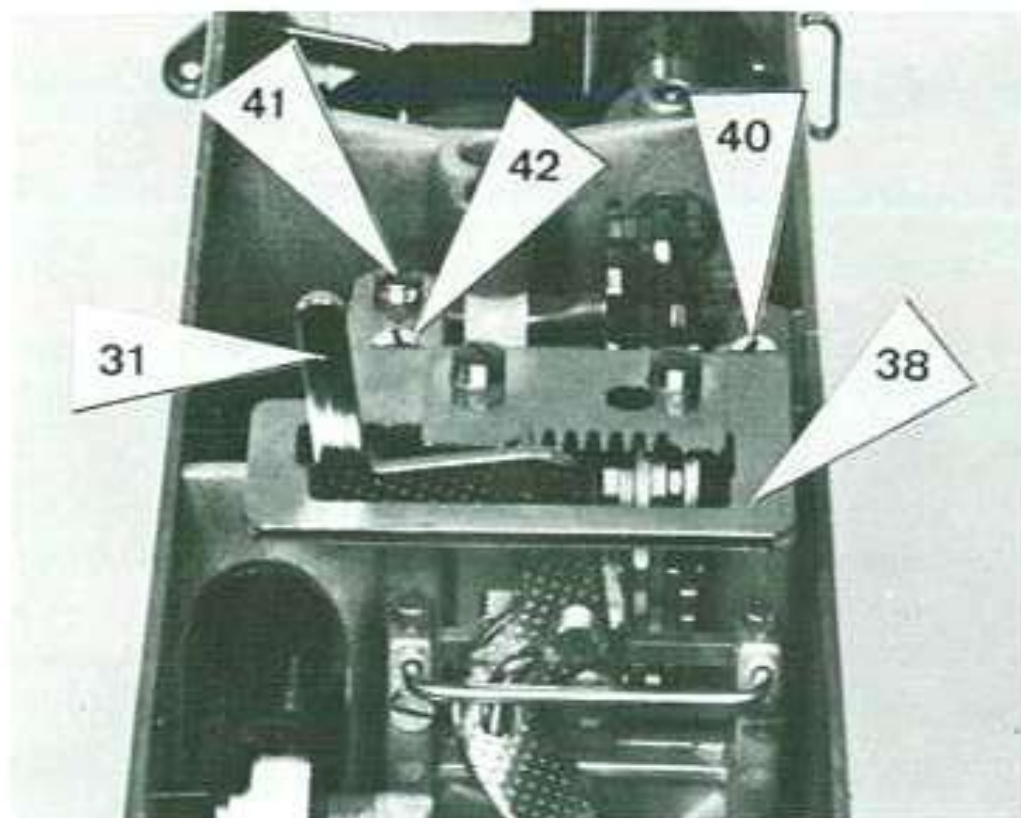

Fig. 12

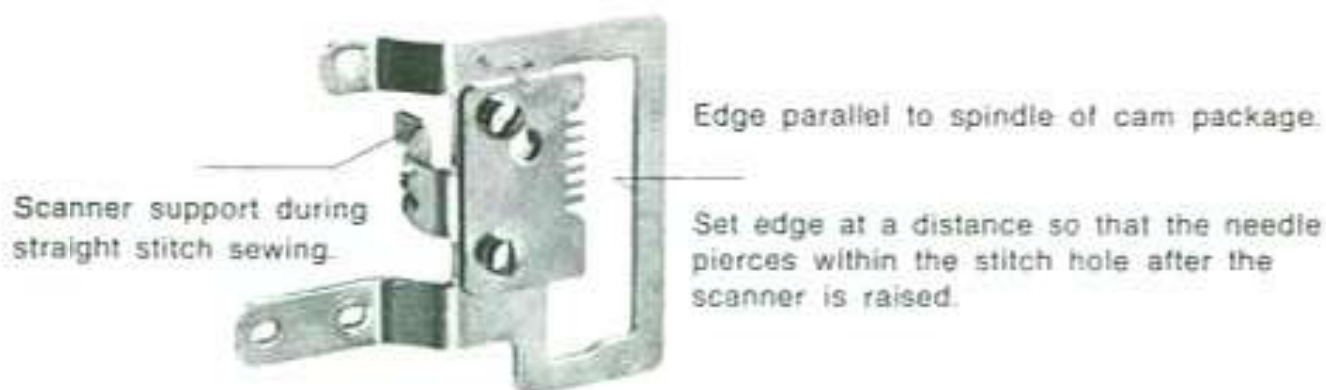

Fig. 13

Setting notched segment

The notched segment (30) is designed to hold the selector lever (31) in the selected position.

The notches must be set laterally so that they coincide with the cams and the scanner on one side and the red mark on the selector lever and the scale on the frame cover on the other.

In order to achieve this it is necessary to move the notched segment sideways, forwards or backwards (depending on deviation).

Best check for coincidence: fancy seam selector lever on No 1 and 6. If there is a discrepancy, the two fixing screws (32 + 33) must be loosened and the notched segment (30) moved to the desired position. Retighten screws

Set notched carrier

When selecting the individual plain stitches the selector lever (31) with scanner (34) is moved from one plain stitch cam to another. Displacement takes place in two movements:

1. Raising of the scanner.
2. Lateral displacement of the scanner.

The scanner must be raised far enough from the cam that it cannot under any circumstances contact a cam when moved sideways. Plate (35) raises the scanner.

If this lifting distance has to be altered, loosen the two screws (36 and 37). Plate (35) can then be set to the desired position.

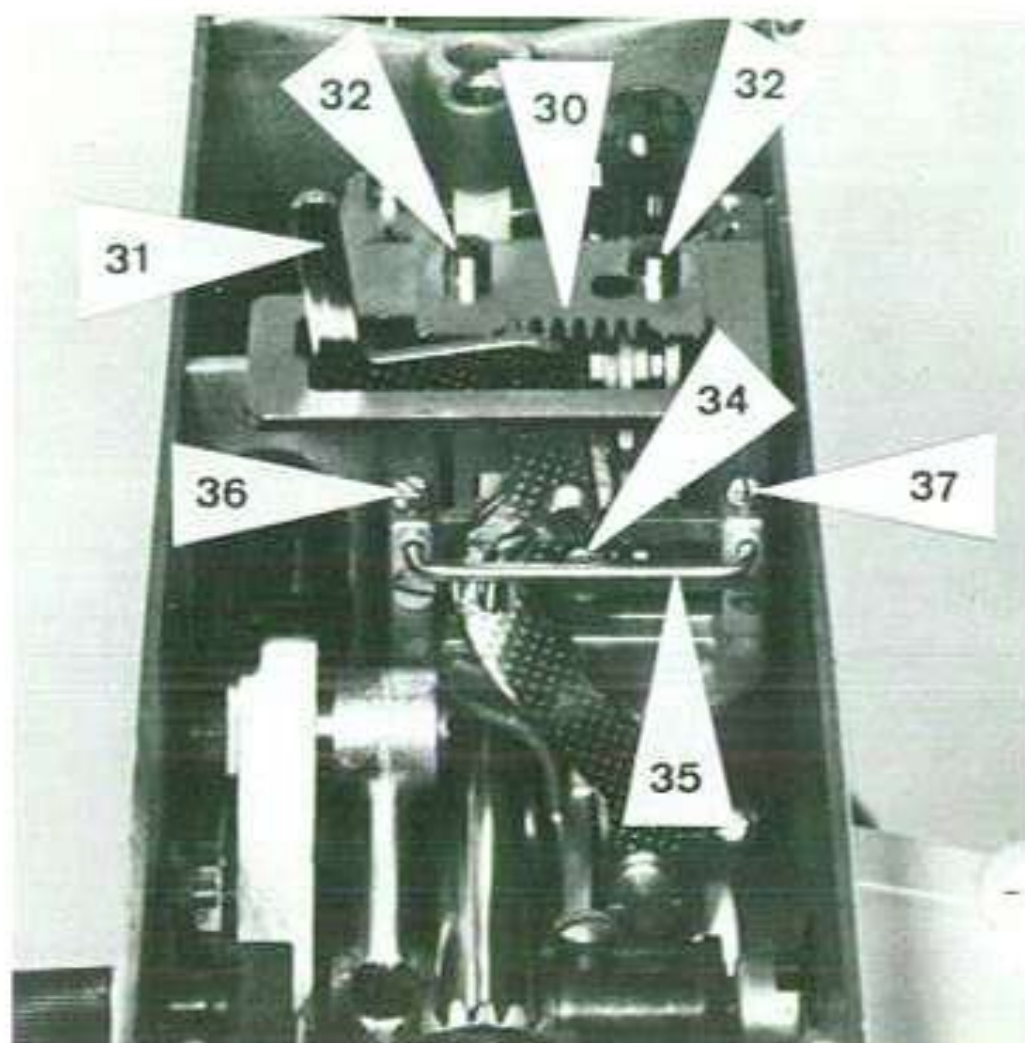

Fig 14

Removing frame cover

Swing over head cover.

The frame cover is disengaged by pressing knob (31) and can be removed.



Fig. 15

Shuttle adjustment — CB shuttle

(CB = central bobbin)

Use a straight needle without fail for adjusting the shuttle.

The thread guide plate is situated above the shuttle race. The lateral needle spacing from the thread guide plate opening should be approx. 0.3—0.4 mm on the right side with maximum zig-zag deflection.

If there is any discrepancy loosen the two screws (52) and fit the thread guide plate as shown.

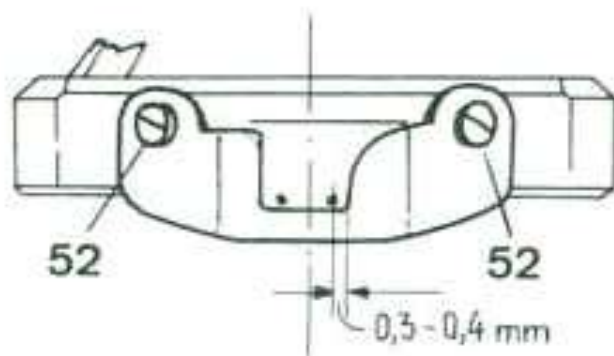

Fig. 16

Thread passage play

For the thread passage there must be a play of 0.3 mm between shuttle (53) and shuttle drive (54). Check with gauge No. 398 022 02.

If the spacing is too great or too small, the short shank of the shuttle drive should be set with the aligning spanner No. 398 020 03 a little inwards or outwards.



Fig. 17

Lateral shuttle adjustment

The lateral spacing between needle and shuttle should be 0.05 mm. If this is greater the result will be faulty stitches, if too small the tip of the shuttle can be damaged.

Correction is performed by shifting the shuttle race. Screw (55) must be loosened. The shuttle race can then be displaced forwards or backwards depending whether

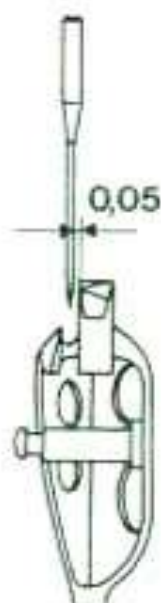

Fig. 18

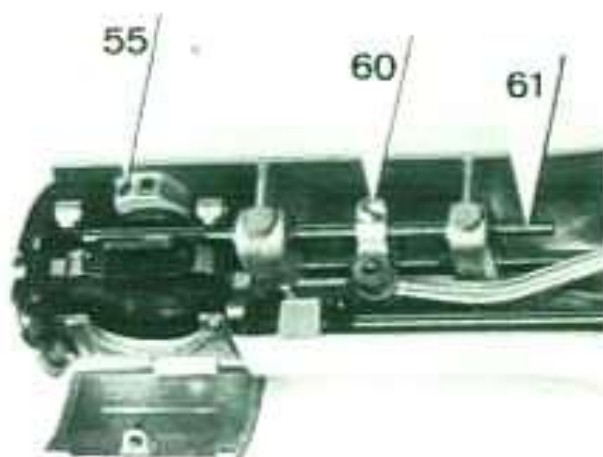

Fig. 19

the needle spacing must be made greater or less. Following proper adjustment re-tighten screw (55).

Ensure that the distance of the needle from the shuttle tip is exactly the same as that between needle and shuttle drive. The shuttle drive must under no circumstances project beyond the shuttle race.

If a «shuttle drive — needle» correction is necessary, the bearing bush (56) of the shuttle race must be shifted. Loosen screw (58) on the rear of the free-arm base and dismantle the shuttle drive together with pinion.



Fig. 20

Insert tool 398 049 04 from the rear of the free-arm base through the shuttle race bore and fit the pin (59). Turn the thrust nut of the tool against the hub of the shuttle race until it makes contact.

The bush (56) can be moved to the rear by turning the knob clockwise.

If correction has to be made forwards, the tool should be inserted from the hinged cover side (or from the front).

Setting the return motion

Two settings may be necessary:

I. Correction owing to inaccurate adjustment:

Use a good needle, system 705 B, No. 80 for the adjustment.

Set needle deflection to left-hand stitch (zig-zag to «0»).

Set rack to forward dead point, loosen screw (60) from rack follower.

Axial displacement of rack to the left = wider return motion.

Axial displacement of rack to the right = narrower return motion.



Fig. 21

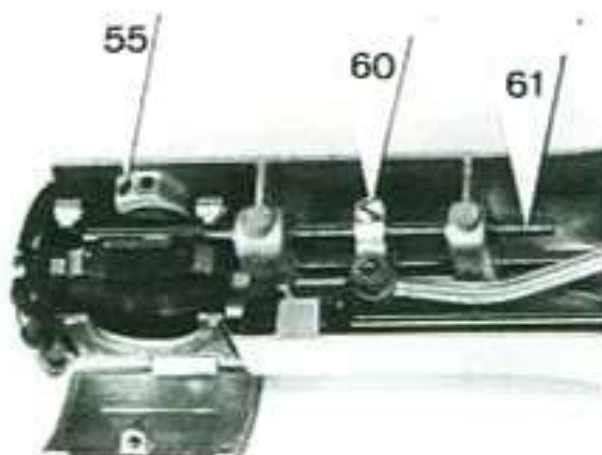

Fig. 22

The spacing is correctly set when the distance between the shuttle tip and the left-hand edge of the needle is 3 to 3.2 mm (gauge 398 090 03).

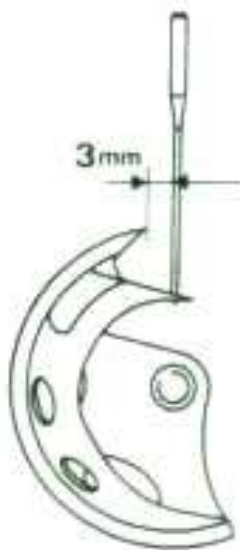

Fig. 23

Secure the toothed rack dog and check the driver for smooth running.
Screw out flat headed screw (58) on the driver spindle and move the spindle.
If there is any sticking it should be eliminated by radial twisting of the toothed rack (61).
Replace screw (58) and tighten.

II. Setting the return motion after dismantling the toothed rack and when exchanging a pinned shuttle drive

Loosen toothed rack dog screw (60) and set to forward dead position. Set toothed rack approx. 3 mm from base wall and turn the teeth to the horizontal position (also insert shuttle drive).

Secure rack dog, again remove shuttle drive and set approx. centrally between the two rack bearings.

Insert the shuttle drive in the race so that the thread outlet side (short shank) lies slightly below the left-hand bore in the shuttle race.

The remaining adjustment is made as described in point I.

Loop lift

The loop lift is the path traversed by the needle from its lowest point until the moment when the shuttle tip enters the thread loop.

Model 807/817 and variants:
loop lift = 2.2 mm
(return motion 3.2 mm)

The loop lift is set on **left-hand stitch** with the aid of the loop gauge No. 398 008 04 (63).

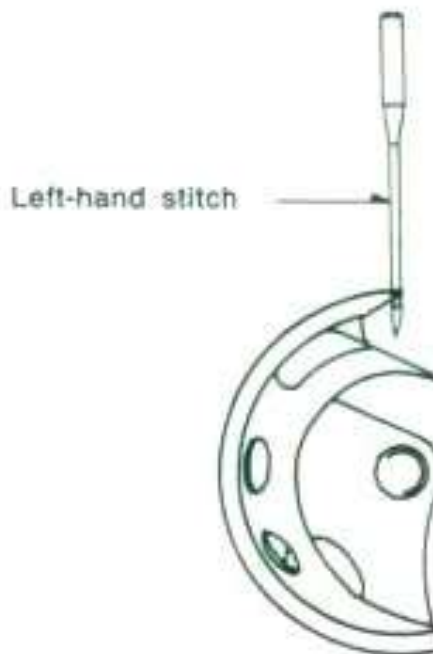

Fig. 24

Set needle bar to lowest position.
Insert loop lift gauge (2.2 mm) beneath the swivel support and raise needle bar by turning handwheel until clamping piece (64) contacts the swivel support (65) (Fig. 25).

In this position the shuttle tip must be at the same level as the right-hand edge of the needle (Fig. 24).

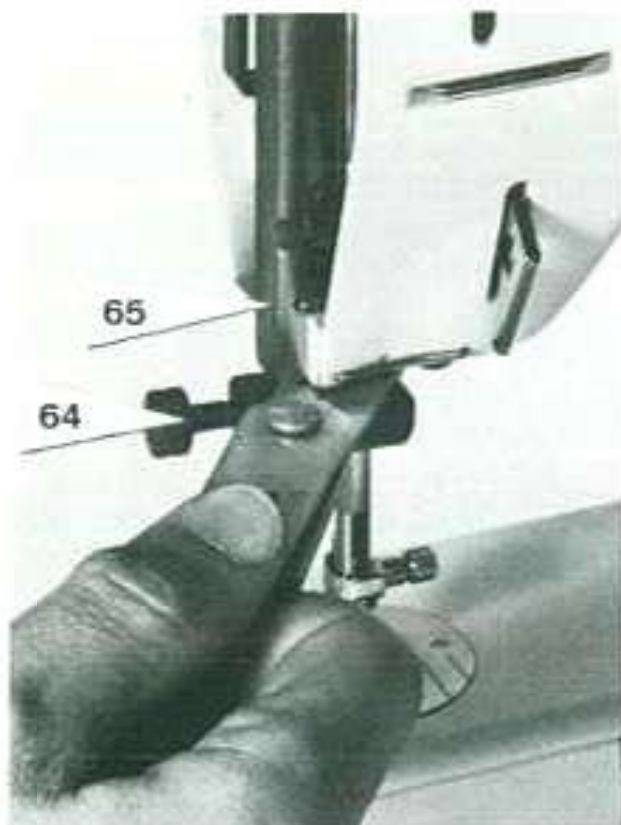

Fig. 25

If correction is necessary, loosen the two screws (66, 67) on the lift crank (68). Then by turning the lift crank (68) the shuttle can be set using the shuttle drive so that the shuttle tip intercepts the right hand needle edge. Then tighten screw (66) and recheck setting. Remove clam-

ping piece and turn the lift crank until screw (67) is accessible. This is a pointed screw and should, therefore, only be tightened when the required setting is obtained. Ensure when tightening the screw that the lift crank is not pushed downwards onto the vertical spindle in order to prevent play between crank and vertical spindle.

Needle height

(adjusting needle bar)

The final needle height should be set after setting the loop lift. The needle pierces on **right-hand stitch**.

After the loop lift is completed the lower edge of the shuttle tip should intercept the upper edge of the needle eye (Fig. 27).

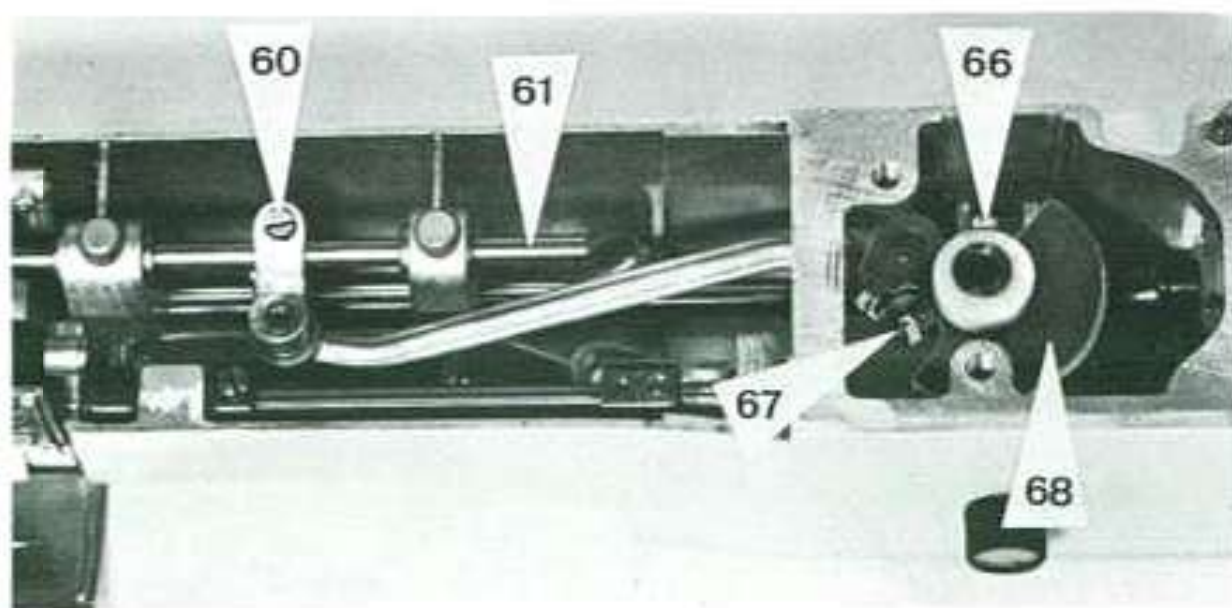
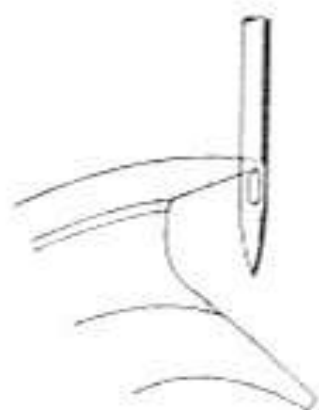

Fig. 26



LMR

Fig 27

To correct, loosen the clamping screw (70) of the needle bar dog (71) and set the needle with needle bar to the specified position.

Caution The needle bar must not twist!

Possibly check with a double needle.
Finally retighten screw (70).

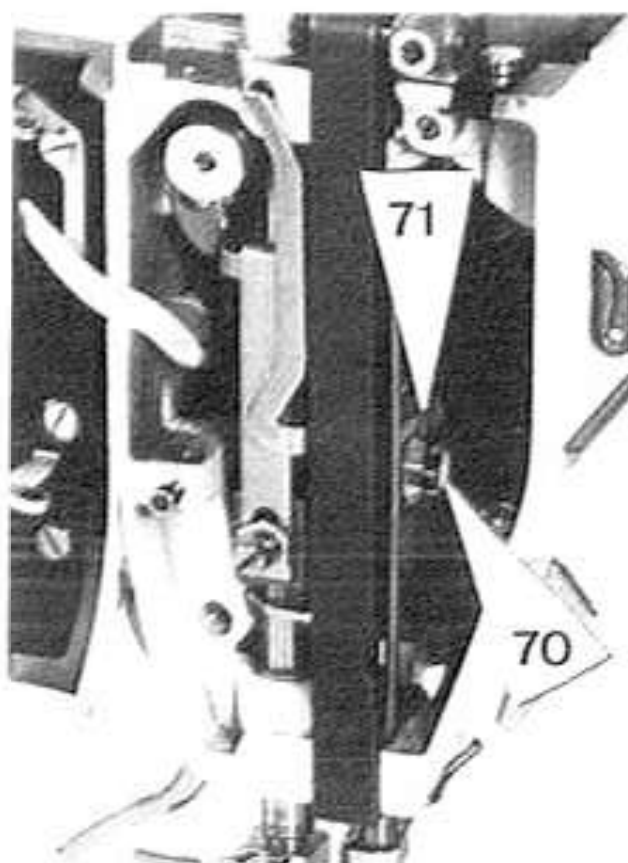

Fig 28

Material feed

Feed dog in the needle plate

The feed dog (toothed section) must be able to move in the feed dog slot without any sticking.

Even with maximum stitch length there should be sufficient space at front and rear in the needle plate.

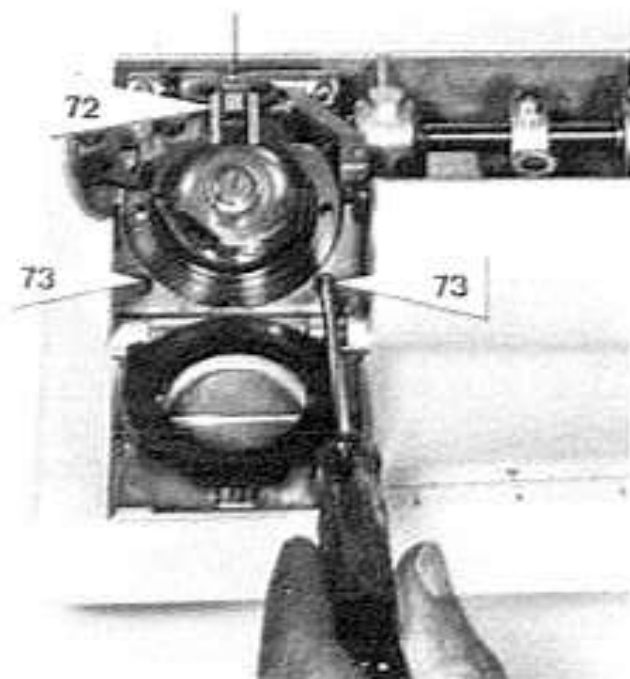

Fig. 29

If the feed dog (72) has to be reset, the two screws (73) must be loosened.

The feed dog can then be shifted in the longitudinal direction and laterally. Retighten screw (73).

Check with the feed dog lowering knob whether the feed dog can be raised and lowered without sticking.

Height of drop feed control

The tips of the feed dog teeth should project 1.0—1.1 mm over the upper edge of the plate at the highest position.

Check correct setting with gauge 398 027 030.

Turn drop feed lowering knob to «sewing» position.

Place adjustment gauge with the existing notch on the needle plate (1.1 mm at front, 1.0 mm at rear).

Set the longest stitch.

The required drop feed height can then be checked.

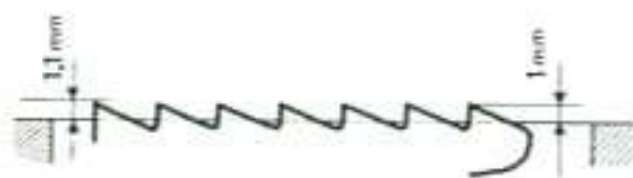

Fig. 30

If correction is necessary, loosen the two screws (75) of the half coupling (74). The latter can then be turned forwards and backwards and the drop feed is raised or lowered. Retighten screws (75) and place cover plate in position.

Check the distances again with the setting gauge 398 027 030.

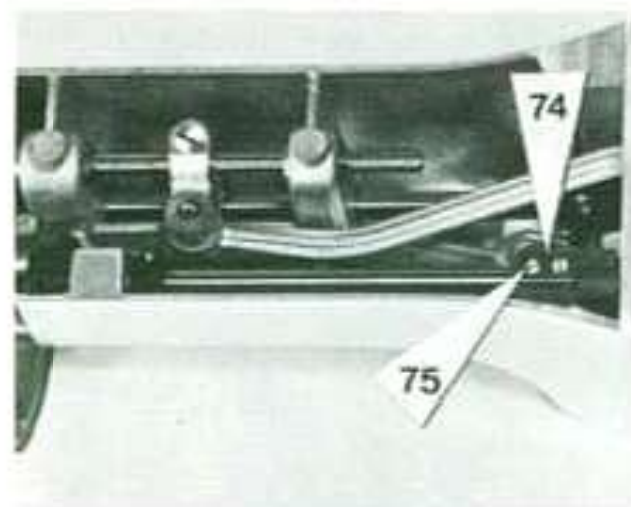

Fig. 31

Depth limit stop for drop feed

The adjusting ring (76) acts as a limit stop for the drop feed at its lowest position.

The lowest point of the feed dog should be limited so that it cannot touch the thread guide plate under any circumstances.

Set drop feed lowering knob to «sewing» (couple).

Bring the drop feed to its lowest position by turning the handwheel.

Disengage drop feed, i.e. set the drop feed lowering knob to «darning».

There should then still be approx. 0.2 mm play before the setting ring (76) with stop limits the downward motion.

Loosen screw (77) if necessary and fix setting ring (76) with stop in the prescribed position. Ensure when re-setting that no axial play exists.

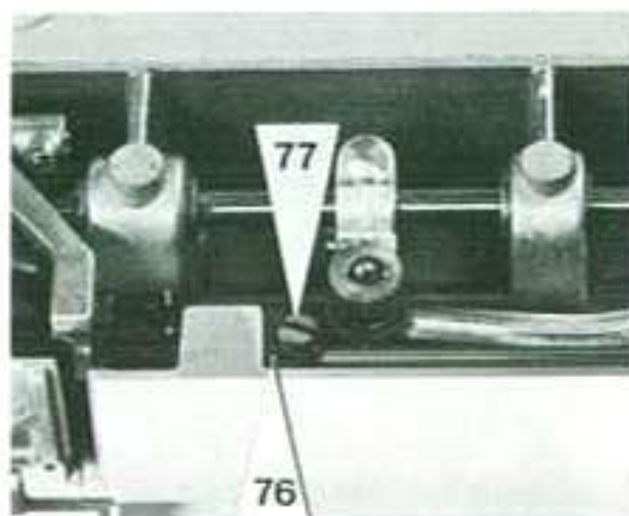
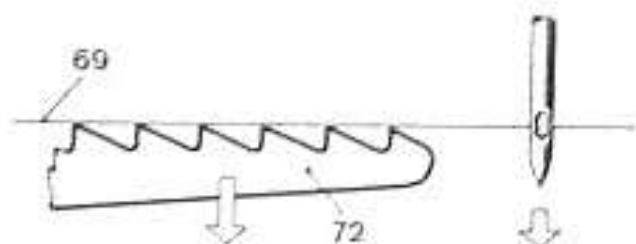

Fig. 32

Drop feed lift

Raising and lowering of the drop feed must synchronise properly with the needle motion. With the base cover plate in position turn the handwheel until the eye of the needle intercepts the upper edge of the needle plate (69).

Fig. 33



In this position the rear-most row of feed dog teeth must no longer project beyond the needle plate while, at the same time, the drop feed should be moving downwards.

As already stated above, the timing of this drop feed motion is synchronised with the needle motion. When loop lift, return motion and needle bar height have been correctly set, the lowering of the drop feed occurs at the right time.

There are no other possibilities for correction.

Drop feed advance

Just as the raising and lowering of the drop feed must synchronise with the needle, the same is true for the advance of the drop feed.

Set the stitch setting lever right down (longest stitch) and turn the handwheel until the take-up lever is at its top position. Place a needle on the needle plate beside the row of teeth so that the tip of the needle fixes the position of the rear-most row of teeth.

Continue turning handwheel. The drop feed must then advance a further $\frac{1}{4}$ —1 tooth.

Correction: Loosen the screws (78) of the advance eccentric (23) mounted on the frame shaft (22). Secure advance eccentric (23) and turn handwheel forwards or backwards depending on whether the drop feed is to advance sooner or later. Then retighten screws (78).

Ensure that the advance eccentric (23) is not displaced axially or otherwise the stitch setting fork (79) could jam.

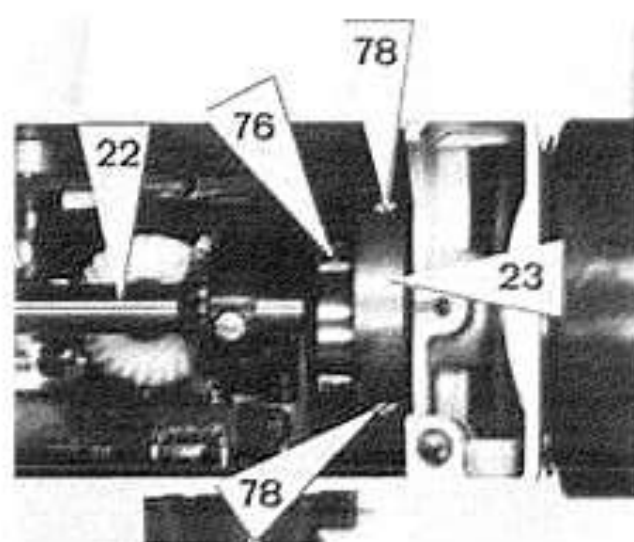

Fig. 34

Presser foot bar

a) Adjustment of presser foot fixing piece

The height of the clamp (80) should be set so that the tension cam (81) of the presser foot is approximately at the center of the tension surface of lever (82).

To set correctly loosen screw (83) and set clamp to the corresponding position.

Caution: The clamp must not be twisted.

Fig. 35

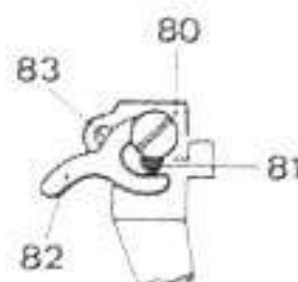

Presser foot adjustment

Lower feed dog, raise lifter lever (86) and attach normal presser foot. Place feeler gauge 398 031 13 (height 6.5 mm) under the presser foot on the needle plate. In this position (spacing 6.5 mm) the material bar guide (84) must lie on the lifter lever (86).

If correction is necessary, loosen screw (85) and set the material bar guide to the required position.

Finally check whether the presser foot sole runs parallel to the needle plate slot. Tighten screw (85).

Lock-nut (85a) remains loose.

b) Setting the darning device

Remove presser foot and attach darning foot. Lower feed dog. Place spacer (10 mm) under the darning foot and lower the presser foot bar. Turn handwheel and set the swivel piece (88) so that the screw (89) points vertically upwards.

Then the presser foot bar dog (84) above the presser foot bar guide is released. This is moved downwards until it lies on the darning lever.

Retighten screw (91) ensuring that the presser foot bar dog does not twist.

When set correctly the distance between darning foot sole and needle plate is 0.5 mm.

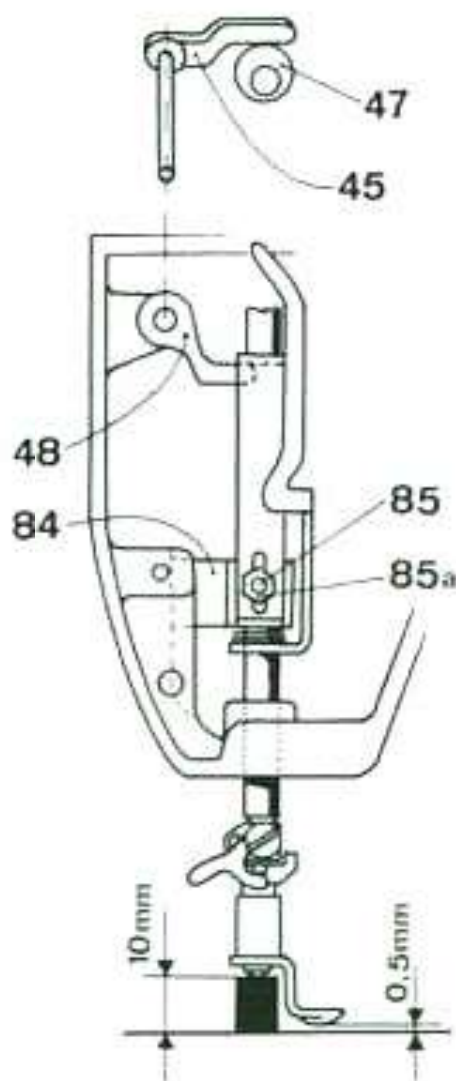

Fig. 36

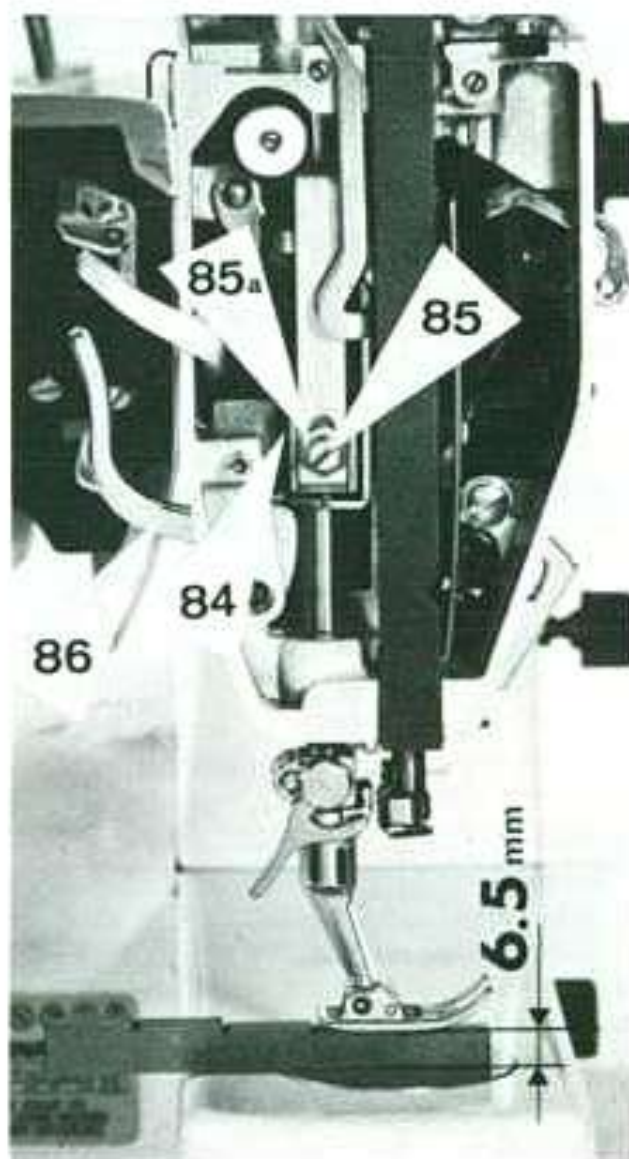

Fig. 36 a

Jumper adjustment

The jumper eccentric (47) on the frame shaft simultaneously acts as a setting ring. The correct position of the jumper eccentric (47) is obtained when the screw

(46) arriving first lies in line with the screw (89) on the swivel piece (88) when the handwheel is turned against it. Both screws point vertically upwards (see illustration).



Fig. 37

Remove presser foot and attach darning foot, lower feed dog. Place spacer (10 mm) under the darning foot and lower presser foot bar. Turn handwheel until the needle bar has reached lowest point.

The presser foot bar dog (84) is then pressed down until it lies on the darning lever (48). The long darning lever (45) must lie on the jumper eccentric (47) at the same time.

Tighten lock-nut (85a).

When set correctly the distance between darning foot base and needle plate is 0.5 mm.

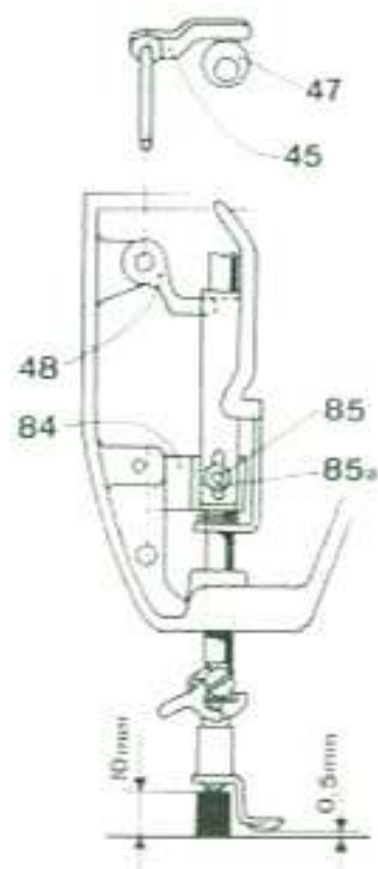

Fig. 38

Adjustment of stitch setting link-zero position

a) Position of stitch length adjusting knob

Turn stitch length adjusting knob (101) to the stop. The red mark on the front of the knob (101) must point vertically upwards. If not set exactly, loosen nut (102) behind the knob and turn knob to the prescribed position.

WARNING! The stitch length adjusting screw must not turn out of the zero position.

b) Zero position of stitch length stop

The mark on the pointer bush (100) must coincide with the figure «0» on the stitch length scale.

In the event of discrepancy, screw (104) should be loosened. (Remove belt cover and gearing. Turn handwheel until screw (104) is visible behind the stitch setting fork and can be reached with a screwdriver).

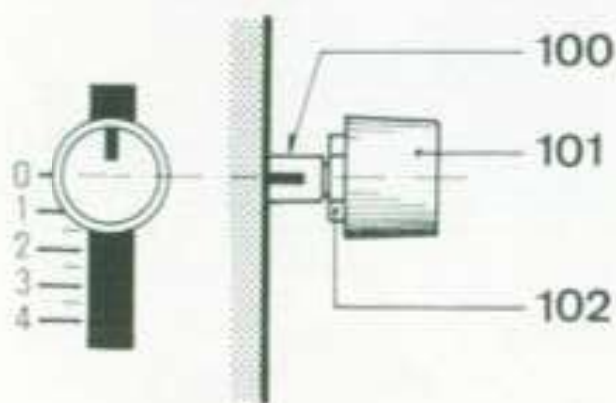

Fig. 39

The stitch length adjusting knob with pointer bush can then be made to coincide with the figure «0» on the scale.

It must be ensured that the marking line on the pointer bush is never set over the zero line on the scale!

Retighten screw (104).

c) Zero position of stitch setting link

Insert needle system 705 B.

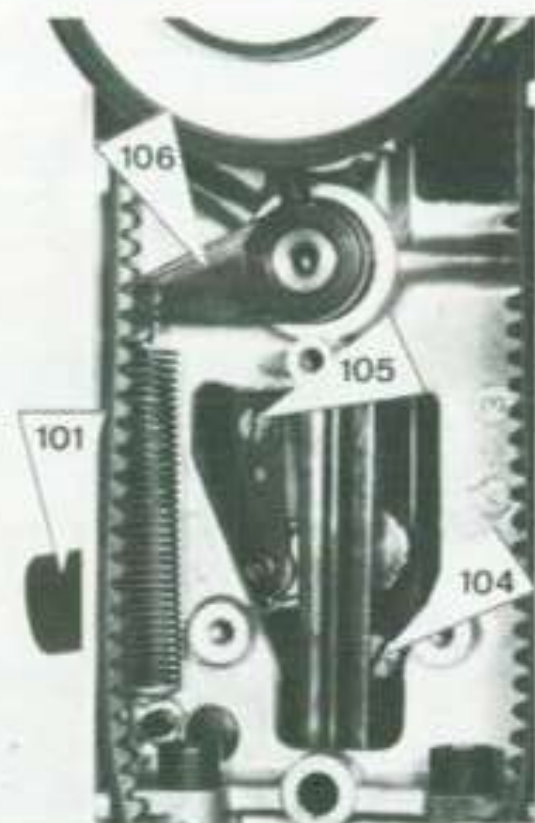

Fig. 40

Place raw cotton-cretonne sewing-in material, 2-ply, under presser foot and allow the machine to run. There must be no feed of the material at full speed.

If the work is fed, the machine must be adjusted as follows:

Loosen screw (105) on the connecting strap. Turn sprung lever (106) with machine running until feed ceases.

Make a further check on feed after tightening screw (106).

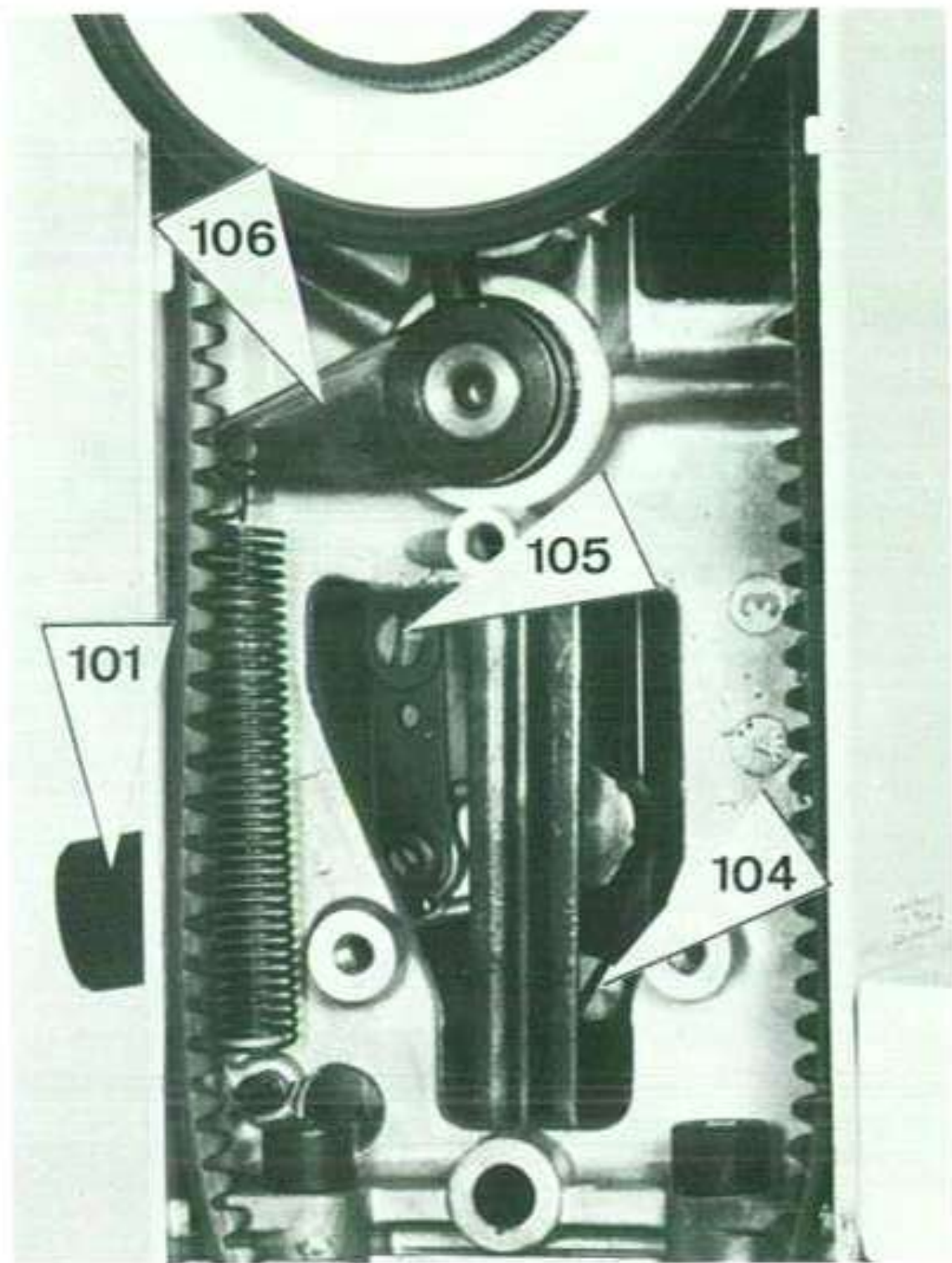

Fig. 40 a

Upper thread tension

Check and adjust the upper thread tension with the setting weight No. 398 080 040 for model 807 (and variants).

The bobbin case yarn contained in a brand new machine should be used as test yarn.

The bobbin with sewing thread No. 60, 3-ply, white, left-twist, is placed on the front reel pin and threaded as far as the take-up lever in its highest position.

Warning: lay the thread to the right of the intermediate disc.



Fig. 41

Approx. 30 cm thread is drawn off the bobbin so that when checking the take-off speed the thread hangs **loosely** between reel pin (133) and diverting eye (134).

The weight is then suspended on the thread and the speed of take-off noted. The thread is correctly tensioned when the weight draws the thread **very slowly**. The permissible take-off speed is 30 ± 10 secs. for a length of 55 mm (length of take-up lever slot, see Fig. 42).

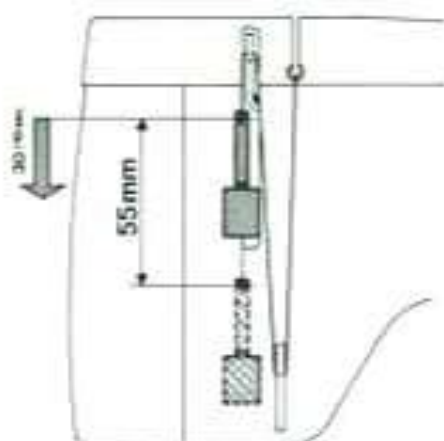

Fig. 42

If the thread tension is set inaccurately, correction should be made as follows:

1. Turn the thread tension nut towards the scale window (reduction of tension) until the weight moves well. The thread between reel pin and diverting eye must be slack.
2. Turn the thread tension nut away from the scale window until the take-off speed reaches the value specified above of 55 mm in 30 ± 10 secs.
3. Adjust the thread tension scale to the mark on the frame cover.

The scale must be as close as possible to the wall but must not touch it.

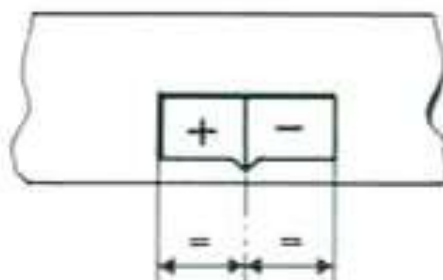

Fig. 43

Lower thread tension

The correct setting of the lower thread tension is made with the aid of various test weights:

CB-shuttle:

darning yarn 120/2
draw-off weight - 18 grams
(gauge No. 398 040 041)

Sewing yarn 60/3:

draw-off weight - 27.5 grams
(gauge No. 398 041 041).

To check the lower thread tension the take-off weight — similar to the shuttle — is placed in the bobbin case. The free end of the thread is held and the case allowed to run with the weight attached. It must be ensured that the bobbin case spring is straight over the entire width and slows the thread evenly.

Tighten the screw (138) more or less firmly to regulate.



Fig. 44

Setting the thread regulator

The thread regulator spring (139) should lie on the limiter (140) at the instant when the eye of the needle enters the work.

The stop (140) can be set to the correct position by turning screw (141) (Fig. 46).

The tension of the regulator spring (139) is also important. This must neither be too loose nor too tight. The correct setting is obtained when the spring (139) takes off the thread with the necessary -liveliness-. The tension can be made stronger or weaker by turning screw (141) to left or right.

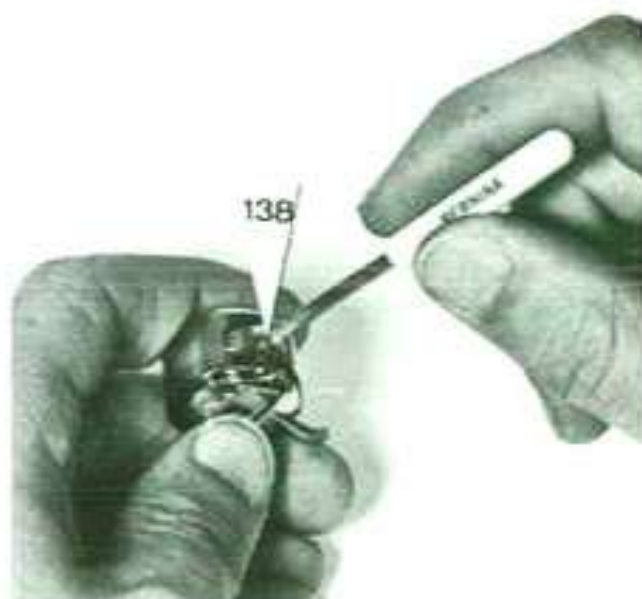

Fig. 45

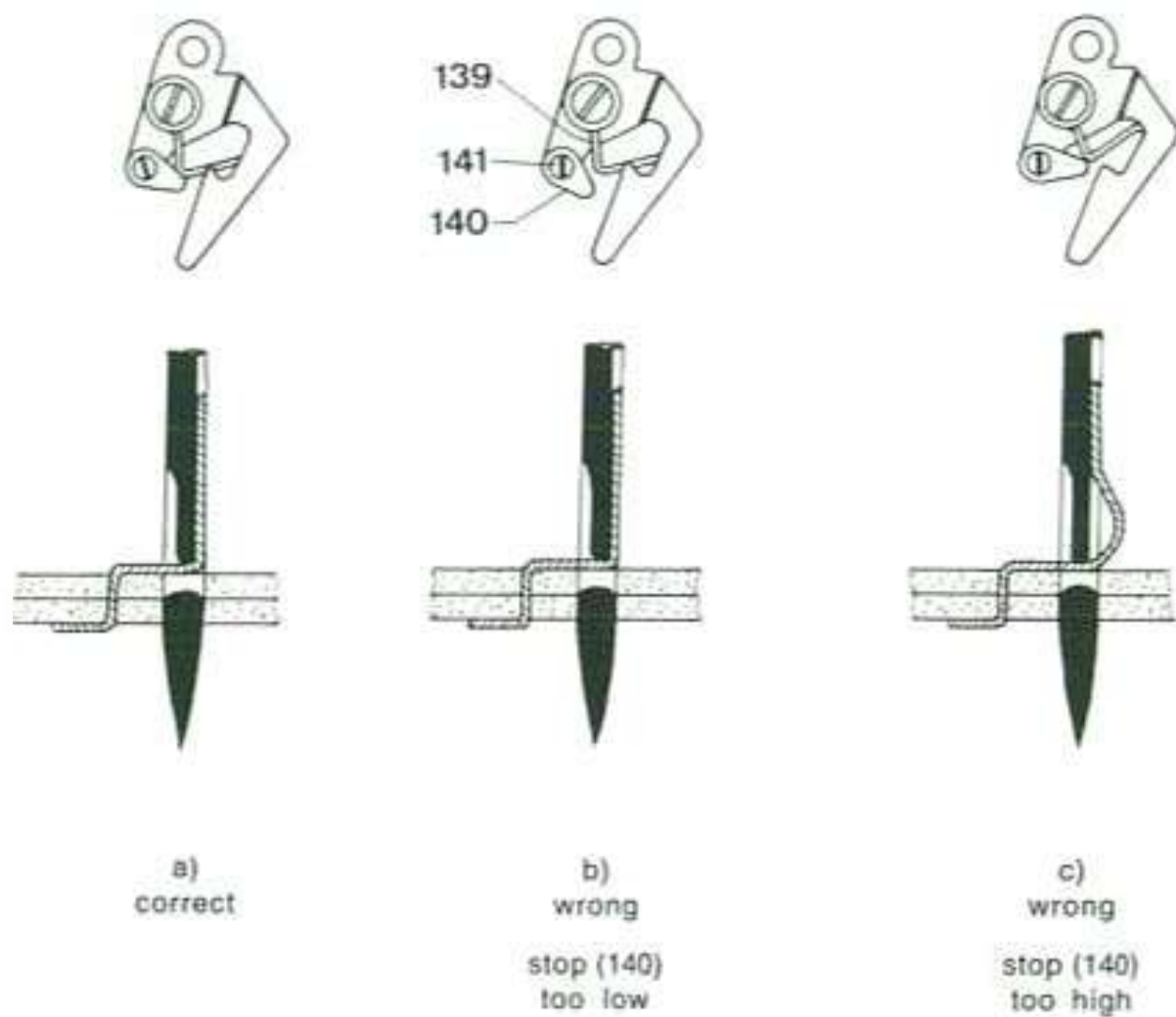

Fig. 46

Regulation of foot pressure.

If necessary the presser foot pressure can be regulated with screw (143).

Factory setting = 1200 grms.

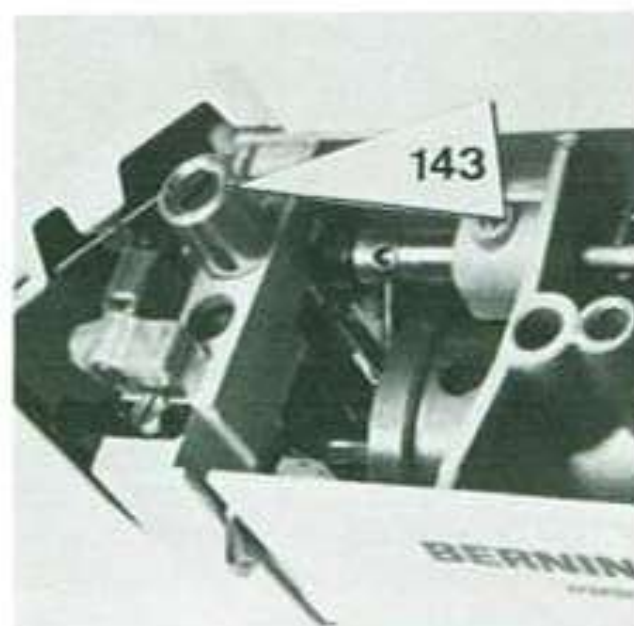

Fig. 47

Drive

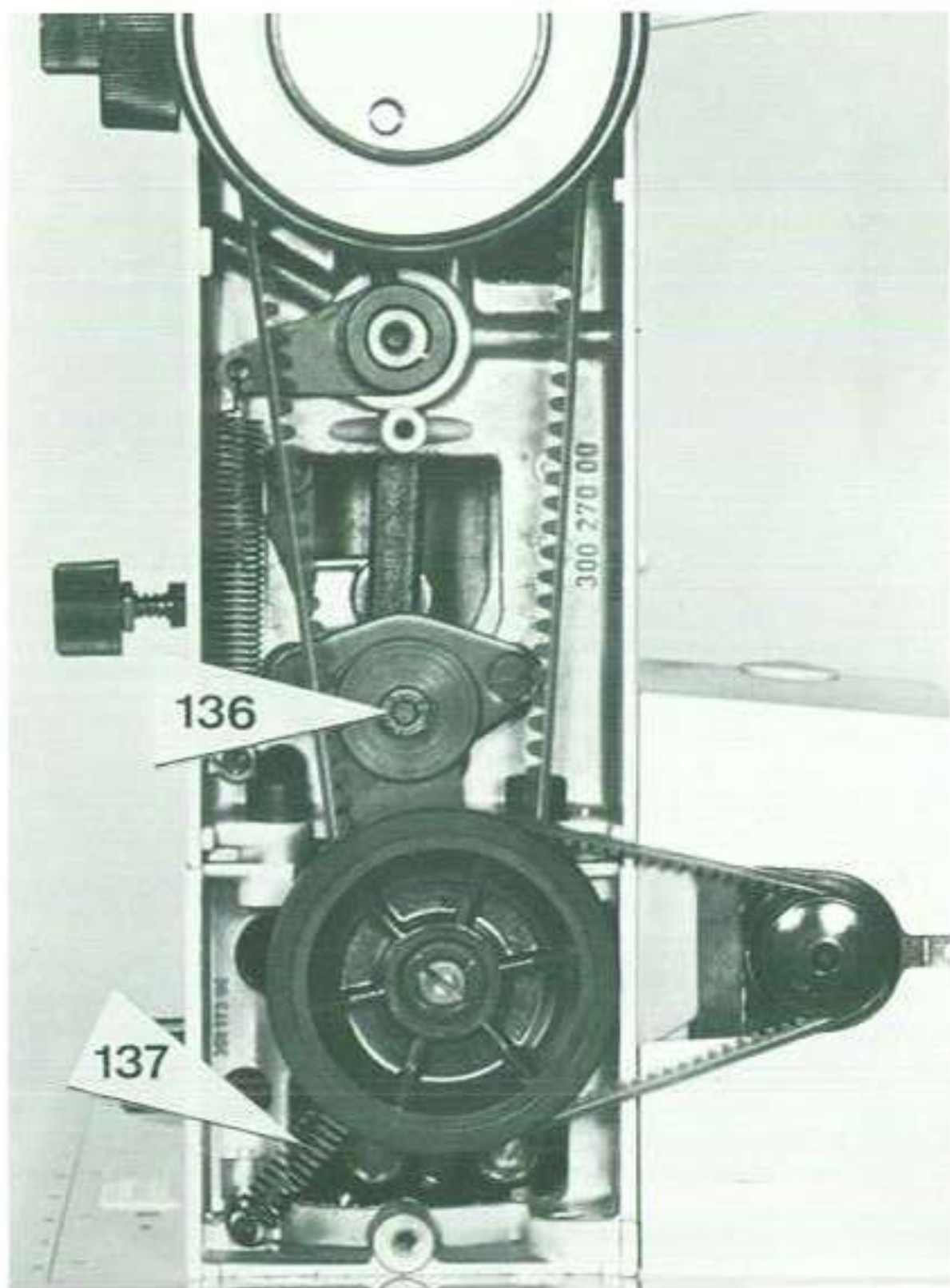

Fig. 48

Model 807 drive (and variants)

Exhaustive tests have been carried out with various V-belts to improve the power transmission from motor to machine.

The best result was obtained with the new, inside-teeth, POLYURETHANE V-belts.

V-belt, long

section 6 x 4 mm No. 305 201 130

V-belt, short

section 5 x 3 mm No. 305 158 132

Re-tensioning the driving belt

Remove belt cover. (Fig. 50).

Loosen screw (136) slightly with socket spanner. Turn handwheel back and forth. Retighten screw (136).

The spring (137) draws the gearing into the correct position and thus produces the prescribed belt tension.



Fig. 50

Electrical fittings

Motor input model 807 (and variants):
85 W.

Sewing lamp: 15 W.

Important:

The machine must be disconnected from the supply by withdrawing the plug from the socket before carrying out repairs or servicing.

Replacement of carbon brushes

To change the brushes the motor with case must be dismantled.

Ensure when inserting new brushes that the semi-circular end matches the round surface of the commutator.

Conversion of machines with resistance regulator (carbon pile) to electronic sewing speed regulator

Release motor housing with motor from baseplate. Remove cover from motor housing. Rewire to Fig. 51.

1. Take out entire changeover switch (150) and diode in baseplate with cable (151). The resulting hole in the baseplate by the changeover switch must be filled with a plastic insert No. 302 225 031.
2. Motor cable (154) from plug contact 5 to contact 4.
3. White capacitor cable (153) from plug contact 1 to 5.
4. Resistor (152) to contacts 1 and 5.
Re-assemble motor and housing.

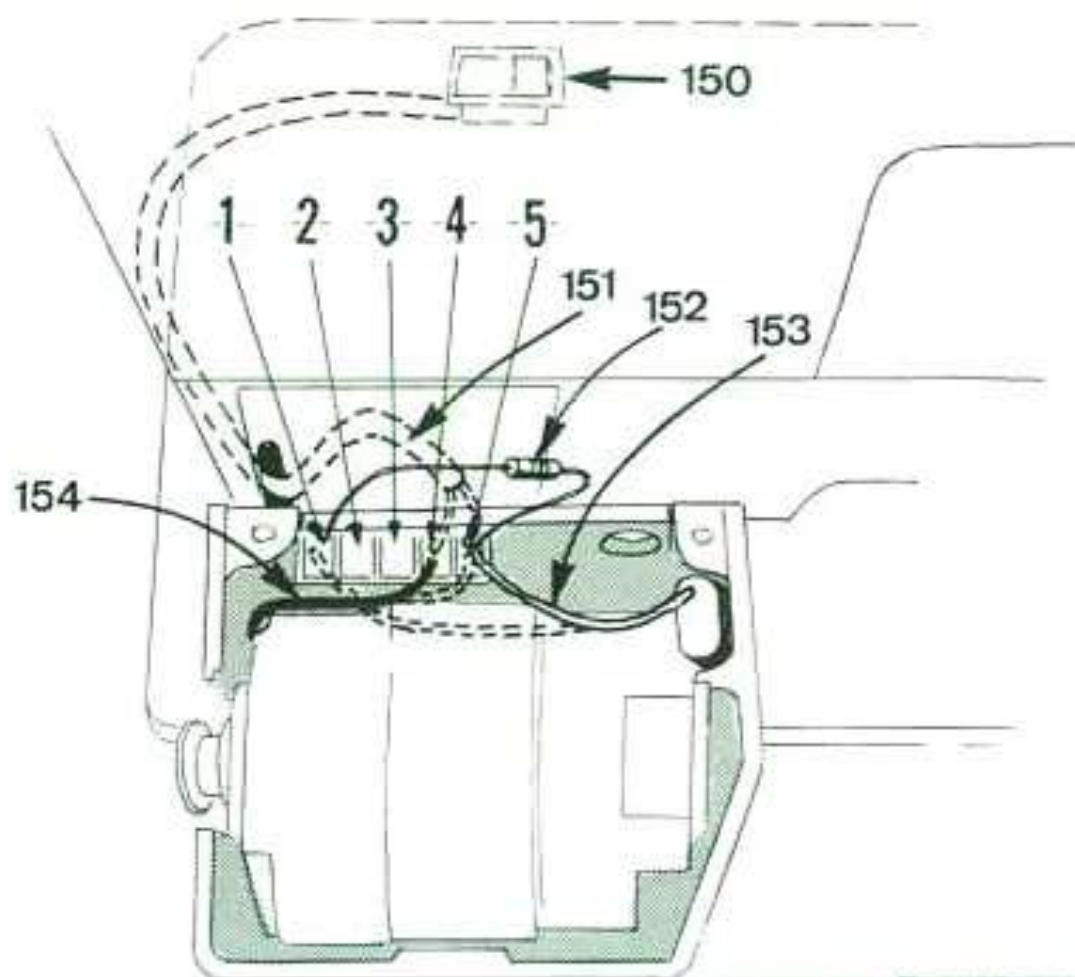

Fig. 51

Electronic sewing speed regulator (foot starter)

Connect machine and regulator to mains supply. Press regulator treadle lightly until the supply is fed to the machine (motor hums). The moment of switching on can be heard when the starter switch closes.

If the motor does not then begin to rotate slowly or fails to start at all, the following procedure must be adopted:

Adjust the trimmer inside the regulator case with the small screwdriver.

The motor can be made to start by carefully turning to the right.

Ensure the needle motion is even, it must not be jerky.

(The motor runs really smoothly at about 150—180 stitches/min.).



Fig. 52

If the motor runs too fast when switched on, the trimmer must be turned to the left with the screwdriver until the correct speed is attained.

This adjustment adapts the regulator to the machine.

We would point out that when ordering an electronic regulator the associated cable and the required resistor No. 335 046 04 are supplied at the same time. The existing connecting cable (mains-carbon pile starter machine) can no longer be used.

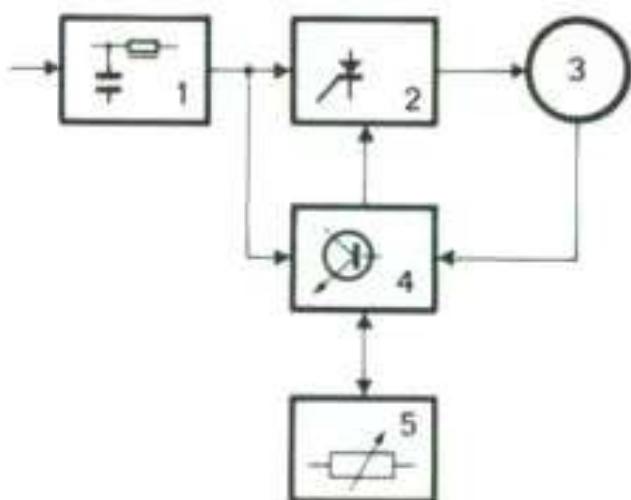

Fig. 53

Block schematic diagram of electronic regulator

1. Suppressor
2. Triac power circuit
3. Motor
4. Phase control
5. Foot starter.

Principle of electronic speed regulation:

The normal carbon pile or resistance starter is not a regulator but only a controller. These starters only vary the speed-power demand is not compensated. Hence the speed varies with increasing or decreasing power demand if the starter position is not changed.

Electronic starters can either incorporate a simple control or the far more complicated regulator. The latter automatically regulates a set speed even though the load changes.

Our new electronic foot starter is a regulator, i. e. it automatically regulates the power demand of the motor for a set number of stitches or even for stitch-by-stitch sewing, so that the machine always runs evenly regardless of the power demand. The degree of regulation offered in the lower speed range is also significantly «finer» than with the previous starter.

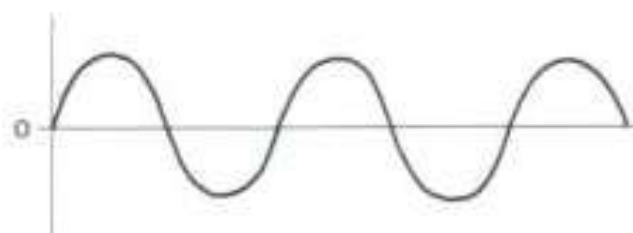

Fig. 54

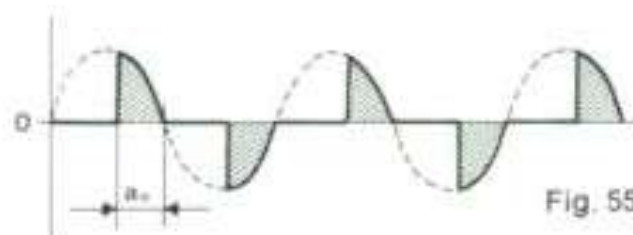

Fig. 55

The motor speed «n» is set with the foot starter. The motor receives a certain fraction « a_n » of each half-wave of current from the electronic unit depending on the starter setting.

As the load increases the motor issues an immediate «command» to the electronic unit for regulation to ensure that the set speed does not fall. The fraction « a_n » is increased by an additional amount « b_n » to keep the set speed practically constant.

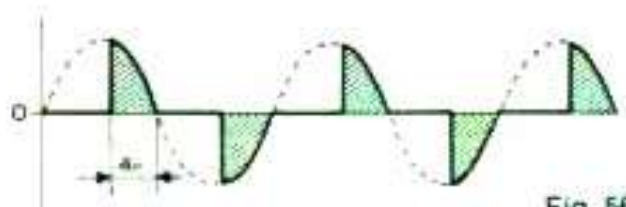

Fig 56

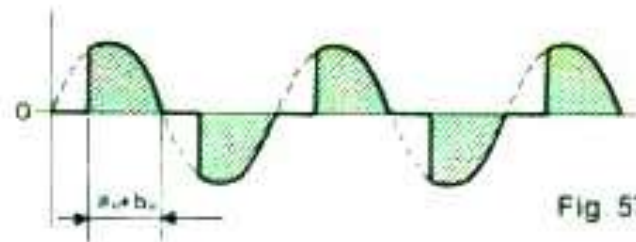

Fig 57

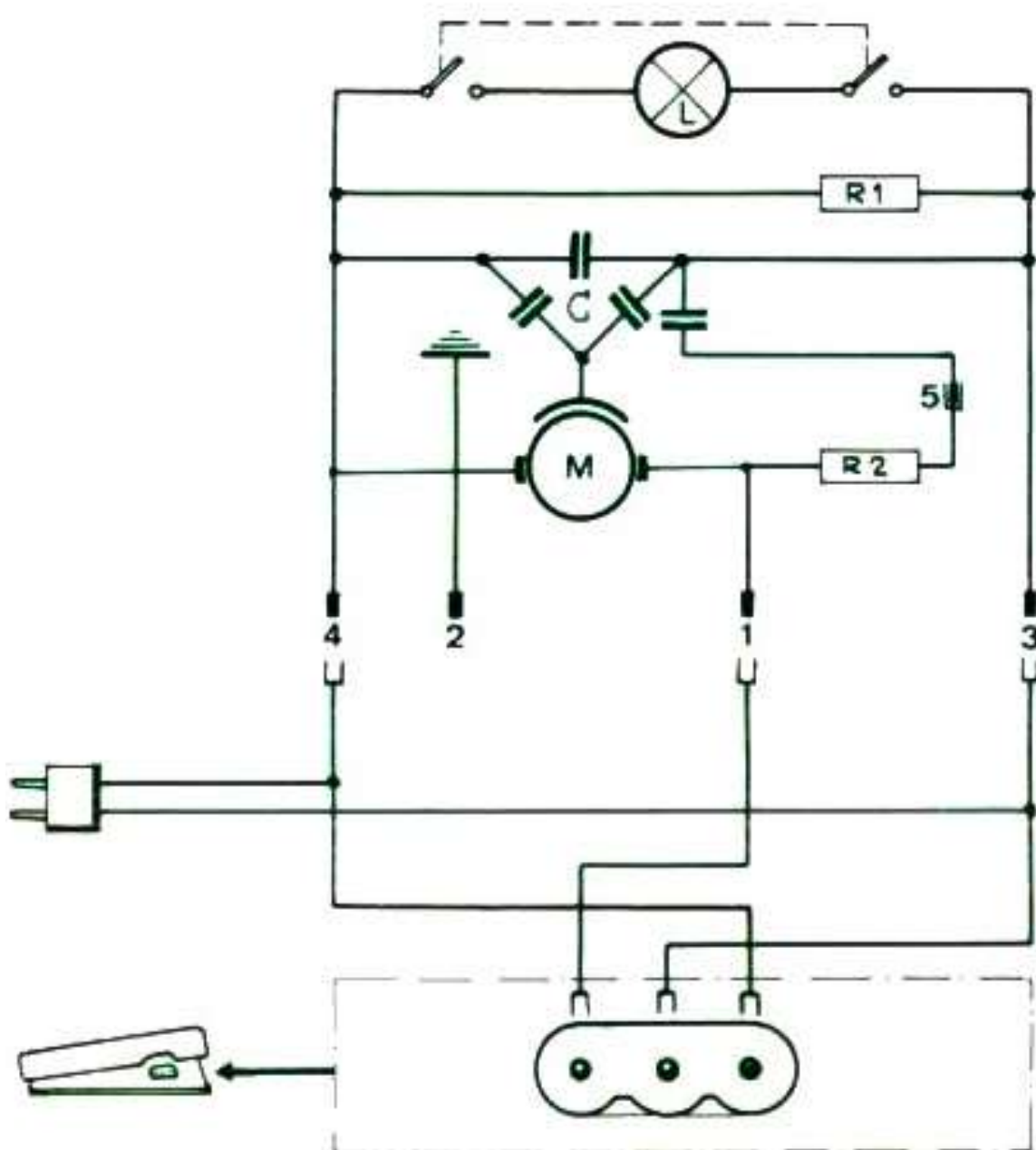

Fig 58

BERNINA Nähmaschine

Schaltplan

Entstörfilter / und Kabelbelegung

Abbildung für BERNINA 800/830 Record Modell-Baureihe

Schaltung auch für 707 und ältere Modelle identisch...
(dann mit anderem Fussregler.)

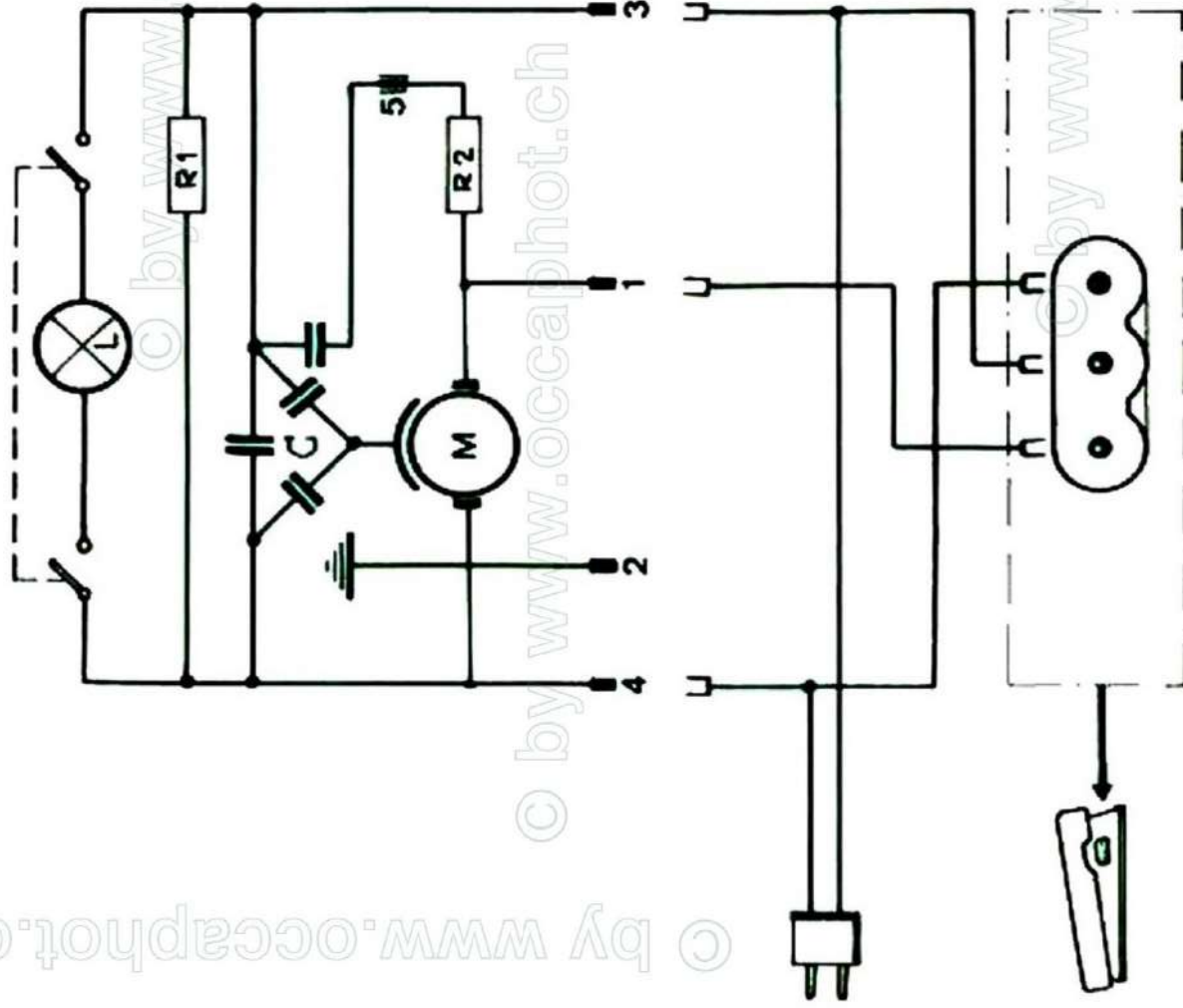

Schalter / Lampe

Entlade Widerstand

Entstörfilter

Geräte-Steckdose
an der Maschine

Netz- Anschlusskabel

Fusspedal Anschluss

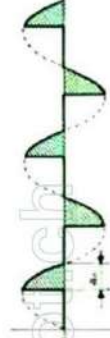

Spannung im Betriebszustand

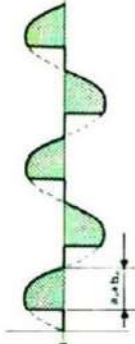

Spannung im Leerlauf

Fault avoidance

1. Basic principles

In the great majority of cases faults can be attributed to improper handling of the machine. Should other causes be suspected, however, the machine must be examined as to whether:

- a) The needle is properly fitted. The long groove must always be at the front from where the machine is threaded.
- b) The right needle size is being used, needle No. 70 for fine darning work and No. 80 or 90 for other sewing work.
- c) The machine is properly clean. Remove free-arm cover plate and clean away all sewing dust, clean feed dog with brush.
- d) The shuttle race is properly clean.
- e) The shuttle race is lubricated with a few drops of oil.
- f) There are no remnants of material between the thread tensioning discs.
- g) There are no remnants of material stuck underneath the bobbin case tensioning spring.
- h) The machine can be turned easily with the handwheel.

2. Thread breakage at the upper thread can be caused by the following:

- a) Use of poor quality, badly polished needles. Needles should always be bought from the BERNINA dealer.
- b) Needle wrongly fitted. Long groove must be at front.
- c) The needle is blunt or bent
- d) The relationship of thread thickness to needle is not correct.
- e) The tension of the upper thread is too great.

f) Poor yarn or yarn with knots. Yarn has dried during long storage. It should never be stored in heated rooms.

g) The needle plate hole has been struck by the needle and must be re-polished.

h) The shuttle tip is damaged.

3. Lower thread breakage can be caused by the following:

- a) The lower thread tension is too great.
- b) The lower thread is badly wound.
- c) The bobbin is crushed and jammed in the case.
- d) The needle plate hole has been struck by the needle and must be re-polished.

4. Missing stitches can be caused as follows:

- a) Use of wrong needle. Use only needle system 705.
- b) Needle is bent.

The following wrong adjustments on the machine can be the cause of missing stitches:

1. Lateral spacing between needle and shuttle is not right. It must be 0.05 mm (see page 12).
2. Loop lift and return motion are not correct (see page 13 + 14).
3. The needle bar height is not correctly set (see page 15).

In general: always use perfect needles and first-class thread. Also ensure that the needle size matches the thread thickness.

5. Needle breakage

can be caused by the following:

- a) The needle fixing screw is not tightened sufficiently.
- b) The upper thread tension is too great.
- c) The work is drawn out at front from under the presser foot which bends the needle. It should only be drawn out at the rear beneath the presser foot sole.
- d) Needle size and fabric thickness are not properly matched.
Very often needles which are too thin are used with thick yarn which causes the needle to bend.
- e) Use of cheap yarn, unevenly twisted or knotted.
- f) The work should not be drawn too strongly to the rear during sewing.

6. Seam faults

a) Poor, uneven seams are produced:

- 1. When there are remnants of thread between the thread tension discs.
- 2. There are remnants of thread under the bobbin case tension spring.
- 3. The bobbin is crushed and jams in the bobbin case.
- 4. The sewing yarn is of uneven thickness.
- 5. The shuttle is not lubricated.

b) When sewing Tricot it should be noted that:

- 1. Tricot should always be basted with darning thread, not with basting thread.
- 2. Use perfect needles, size 70 or 80.

When sewing with new, synthetic threads it can occur that the normal needle plate must be exchanged for a special needle plate. The BERNINA Sewing Machine Factory is willing to lend you every assistance in solving your particular sewing problem.